

W. VAN ANDEN.
Water Meter.

No. 113,597.

Patented April 11, 1871.

FIG. 1

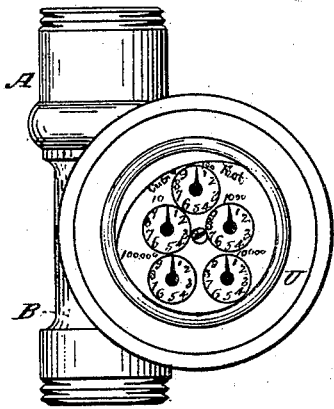

FIG. 2

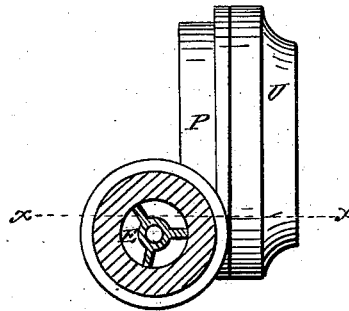

FIG. 3

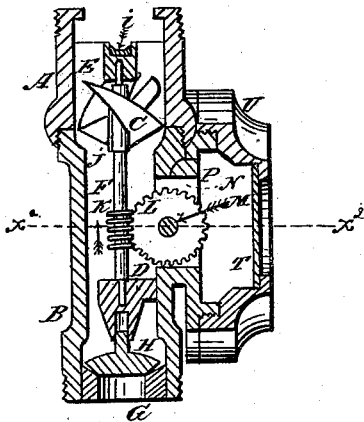

FIG. 4

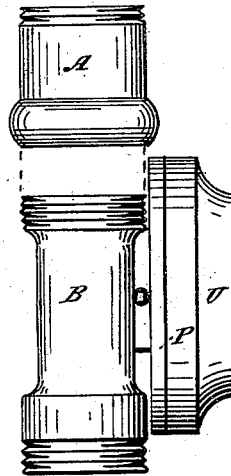

FIG. 5

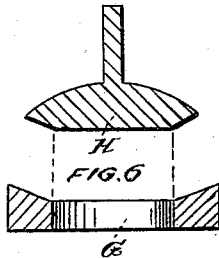

FIG. 6

WITNESSES:

Charles S. Barritt
Franklin Barritt

INVENTOR:

William Van Anden

W. VAN ANDEN.

Water Meter.

No. 113,597.

Patented April 11, 1871.

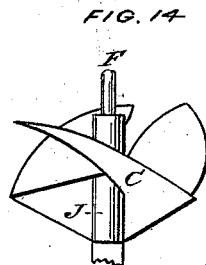
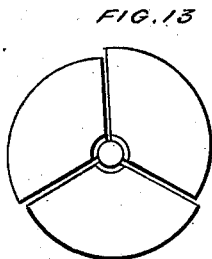
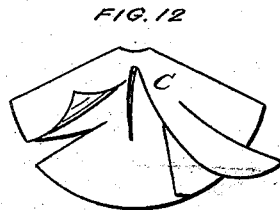
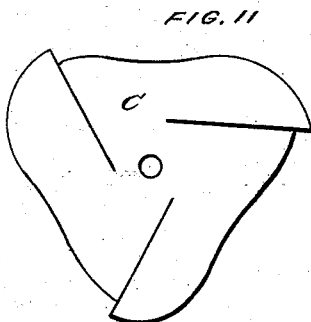
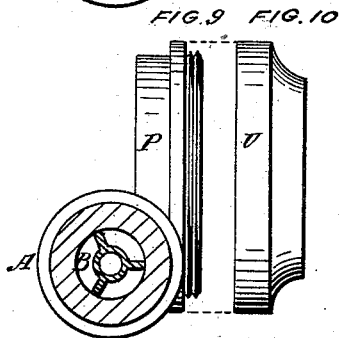
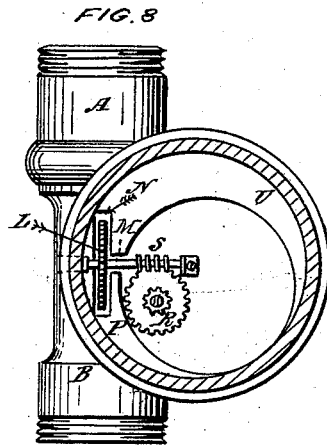
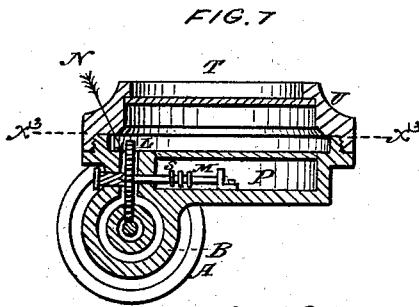

WITNESSES:

Charles L. Barrett
Franklin Barrett

INVENTOR:

William Van Anden

UNITED STATES PATENT OFFICE.

WILLIAM VAN ANDEN, OF POUGHKEEPSIE, NEW YORK.

IMPROVEMENT IN WATER-METERS.

Specification forming part of Letters Patent No. **113,597**, dated April 11, 1871.

To all whom it may concern:

Be it known that I, WILLIAM VAN ANDEN, of Poughkeepsie, Dutchess county, and State of New York, have invented certain new and useful Improvements in Water-Meters; and I do hereby declare that the following is a full description of the same.

The nature of my invention consists in combining with a cylindrical tube a propeller-wheel made from a single piece or blank of metal, whereby the hub and wings or blades are made by the folds of the same by means of dies, and thus avoiding all necessity for screwing, soldering, or riveting the wings to the hub, as generally practiced in making water-meter propellers.

But to describe my invention more particularly I will refer to the accompanying drawing, forming a part of this specification, the same letters of reference wherever they occur referring to like parts.

Sheet 1.—Figure 1 is a front view of the meter. Fig. 2 is an end view of the meter, looking into the exit end of the cylindrical tube. Fig. 3 is a longitudinal cut section of the meter through the line $x x$, Fig. 2. Fig. 4 is a side view of the meter, showing the propeller-tube made in two parts, so as to admit of the quick and easy adjustment of the propeller therein. Figs. 5 and 6 are detached views of the self-acting valve and valve-seat for cutting off the flow of dribblets of water.

Sheet 2.—Fig. 7 is a transverse cut section of the meter through the line $x^2 x^2$, Fig. 3. Fig. 8 is a transverse cut section of the meter through the line $x^3 x^3$, Fig. 7. Figs. 9 and 10 are end views of the meter, showing the cap-plate of the register-box detached. Fig. 11 is a plan view of the blank of metal from which the propeller-wheel is formed. Fig. 12 is a view of the same when first partially folded to form the wings, and hubs or ferrule for securing the propeller on its shaft or spindle. Fig. 13 is a plan view of the propeller. Fig. 14 is a side view of the same.

Letters A and B represent the cylindrical tube or barrel of the meter, composed of two parts, to be joined together by screw-threads, so as to make the barrel for the propeller-wheel.

The object of making the barrel in two parts is to facilitate and quicken the adjustment of

the propeller-wheel C in the barrel. If the barrel was made in one piece, it would involve the necessity of securing the propeller in an independent slide, so that it could be inserted securely in the barrel; but by making the barrel in two parts the bearings D and E of the propeller-spindle F are formed at the time of casting the barrel, and are centered in the lathe at the same time that the barrel is turned or finished off and the screw-threads cut thereon.

It will be obvious, therefore, that making the barrel in two parts will greatly cheapen them over the cost of making them solid—that is, in one piece—and securing the propeller in slides to be inserted in the end of the barrel, and consequently is an improvement on meters so constructed.

On the ends of the barrel are cut screw-threads, so as to admit of its being connected with a supply and discharge water-pipe.

In the induction end of the propeller-barrel is secured a valve-seat, G, having its inner face beveled off so as to admit of the ready adjustment of a self-acting valve, H, thereon to cut off the flow of water when the pressure is not sufficient to rotate the propeller. This will be readily understood by the explanation that the nature of the angles of the wings of the propeller requires a certain amount of pressure to overcome the friction of the registering apparatus. Therefore a small dribbling stream of water flowing from the discharge-pipe about equal in volume to the spaces between the wings of the propeller may be kept constantly running without any registration of the water so drawn off.

To guard against this, the valve H is arranged so as to be self-acting under the pressure of the water, and of such a weight as to cut off the supply of water to the propeller when the pressure on it, owing to the smallness of the stream drawn off, is not sufficient to rotate the propeller.

For the purpose of reducing the friction on the propeller-spindle, a step of glass, I, or other similar substance, is inserted in the outer end of the spindle-bearing E.

It will be obvious that the spindle running on a glass step will greatly lessen the friction; also, that the step can be adjusted to the exact

depth in the bearing with great facility at the time the bearing is being centered in the lathe; also, that it obviates the necessity of cutting screw-threads and screw taps or plugs to hold the glass step in the bearing, as is commonly the case where the glass steps are used for spindles to run on for any purpose; and, lastly, that by securing the step in the bearing by a ring of metal the end of the spindle can always be inspected through the glass step to see that it is properly adjusted and the propeller in running order.

Letter C represents the propeller-wheel, which is made from a single piece of metal.

Fig. 11, Sheet 2, shows the form of the blank of metal, having a hole in the center of it for the propeller-spindle to be inserted therein. When thus shaped it is folded as shown in Fig. 12, Sheet 2. It is then secured upon a rod inserted in the hole in its center, representing the spindle, and by suitable dies pressed so as to form the wings, as shown in Fig. 14, Sheet 2, and a tube or ferrule, J, vertically of it, for the insertion of the propeller-spindle therein to secure them together.

It will be obvious that the precise shape of the propeller-wings, or the angle of their surfaces to the impinging surfaces of the current of water through the meter, or the number of wings formed, is not material so long as the propeller is made from a single blank of metal, substantially in the manner herein set forth.

The object of the invention is to make the propeller-wheel from a single blank of metal, so as to obtain lightness and strength, and thus make a cheap and simple propeller, and at the same time making the attachment of the wings to the hub or ferrule as solid as if made in cast metal, and, of course, much stronger than it is possible to secure the wings to the ferrule by soldering, riveting, or screwing them together.

Letter K is a worm on the propeller shaft or spindle, which gears into a cog-wheel, L, secured upon a center-rod, M, passing through the sides of the registering-box at its junction with the propeller case or barrel, and through the interior of which a slot, N, is cut, so as to admit of the wheel L freely rotating therein.

The object of this arrangement of the slot N is to have the upper edge of the wheel L ex-

tend up into the registering-box P and admit of the rod M, on which the wheel L rotates, extending far enough across the bed of the box P to communicate motion to the series of registering-wheels R by means of the worm S on the rod, to register the amount of water flowing through the meter.

In constructing the registering-box P it will be perceived, as shown in Fig. 8, Sheet 2, that the circumference of it is much greater than the circumference of the countersunk bed for holding the registering-wheels, which is arranged eccentric to the center of the box P.

The object of this formation of the box P is to include all the gear-wheels of the registering apparatus within the box, and thus admit of their being inspected at all times through the lens T in the cap U of the registering-box to see that the apparatus is in working order, and at the same time give ready access to them, if at any time out of repair, by the removal of the cap U by simply unscrewing it.

In securing the cap U on the box by screw-threads it will be obvious that it greatly cheapens the making of the meter-box, as it can all be made by lathe-work, and at the same time obviates the use of bolts commonly used to secure the cap-plate to the body of the meter-box. Where the cap is bolted on the box there is always a tendency to leakages between the bolts when the pressure is about thirty pounds to the square inch, or equal to the pressure of Croton water in the city of New York. By screwing the cap-plate on, the entire surface of the edges of the cap bind upon the packing, and thus make a perfectly tight joint, and at all times easily repacked to prevent leakage.

Having now described my invention, I will proceed to set forth what I claim and desire to secure by Letters Patent of the United States.

I claim—

The water-meter propeller-wheel, when constructed from a single blank of sheet metal to form two or more wings and the ferrule J therefrom, substantially as described, and for the purposes set forth.

WILLIAM VAN ANDEN.

Witnesses:

CHARLES L. BARRITT,
FRANKLIN BARRITT.